



AUTOMOTIVE

PASSENGER CAR

BUILT ON HISTORY **PERFECTED THROUGH TIME**

AUTOMOTIVE FLUIDS AND LUBRICANTS IN USE

Millers Oils prides itself on being able to supply a comprehensive range of engine oils, transmission oils and treatments for the modern passenger car.

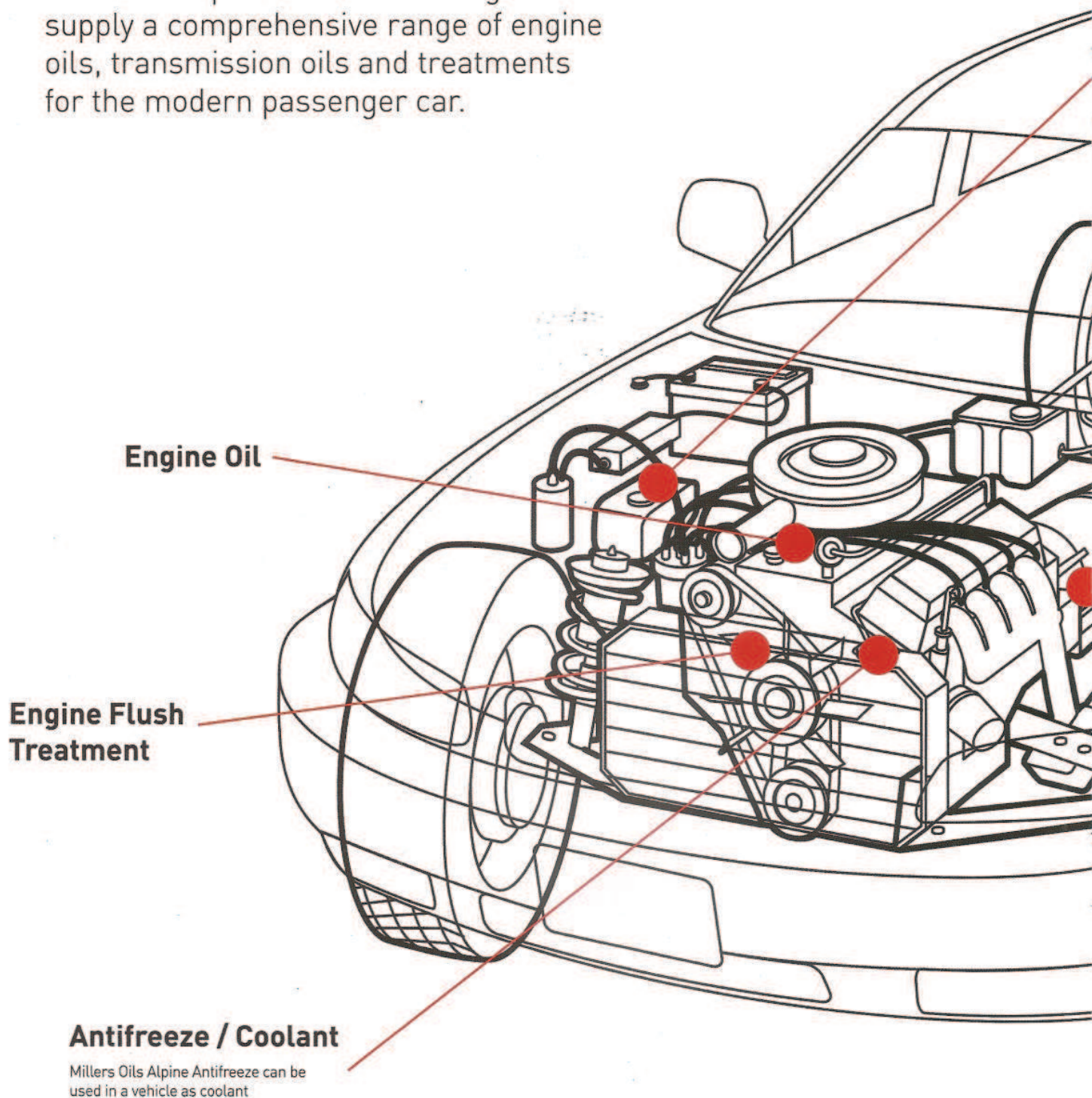

Screen Wash

We have a screen wash product available for use in all road car vehicles

Differential Oil

Fuel Additives

Petrol and Diesel

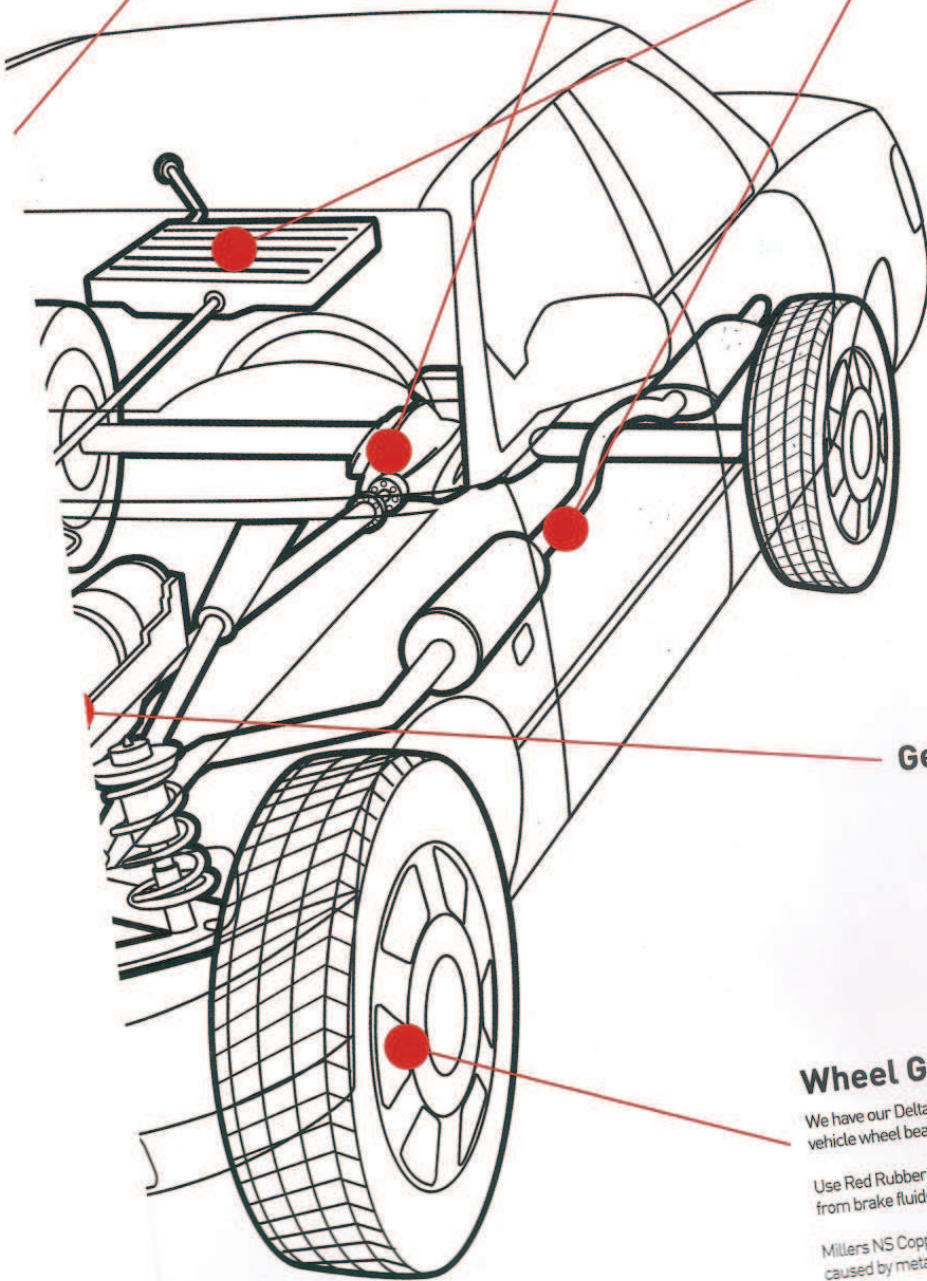

Gearbox / Transmission Oils

Wheel Grease

We have our Deltaplex 2EP grease which can be used on vehicle wheel bearings.

Use Red Rubber Grease to protect seals and gaitors from brake fluids

Millers NS Copper can be used to prevent seizure caused by metal to metal contact, e.g. wheel bolts

INTRODUCTION

Millers Oils is a highly innovative independent manufacturer of market leading advanced oils and fuel treatments with a history of providing creative lubrication solutions for some of the world's best known brands, based on 130 years experience in the lubricants industry.

Although we originated back in 1887, we are continually working towards producing the next generation of high performance automotive products whilst meeting the stringent requirements set by government legislation, industry bodies and car manufacturers.

At Millers Oils, we understand the importance of high performance products that you can trust. That's why our comprehensive range of oils and treatments not only offers outstanding performance for the modern passenger car, but is also designed for longevity and increased fuel economy, helping to reduce maintenance costs and risk of breakdown.

CONTENTS

PREMIUM ENGINE OILS	5-8
PROFESSIONAL ENGINE OILS	9
PREMIUM TRANSMISSION OILS	10-11
FUEL TREATMENTS	12-13
ANCILLARY AUTOMOTIVE PRODUCTS	13
PREMIUM SPECIFICATION CHART	14
PROFESSIONAL SPECIFICATION CHART	15

PREMIUM ENERGY EFFICIENT ENGINE OILS

At Millers Oils we pride ourselves on our award winning innovation, allowing us to formulate products with cutting-edge performance and provide maximum benefit for our customers.

Following the success of our NANODRIVE motorsport range, we took our friction reducing expertise from the race track and applied it to the highway.

Our energy efficient 'EE' engine oil range has been specially formulated with ultra low friction technology, minimising friction losses in the engine whilst maintaining an optimised oil film thickness to lubricate and protect against wear.

For details of our full approvals and performance specifications, please refer to page 14



EE LONGLIFE

5w30

CODE: 7877

A fully synthetic high performance mid Sulphated, Ash, Phosphorous, Sulphur (SAPS) low friction, fuel efficient engine oil. Particularly recommended for use in Volkswagen/Audi Group (VAG) vehicles. Provides a reduction in friction of up to 26% and a reduction in wear of up to 13% compared to other 5w30 VW 504 00, 507 00 grades.

**FULLY SYNTHETIC
ACEA C3**



EE LONGLIFE

5W40

CODE: 7806

A fully synthetic high performance mid SAPS, low friction, fuel efficient engine oil. Suitable for use in VW 'Pumpe Düse' engines fitted to many VAG, and some Ford vehicles. Provides a reduction in friction of up to 32% and a reduction in wear of up to 32% compared to other 5w40 C3 grades.

**FULLY SYNTHETIC
ACEA C3
API SN, CF**



EE LONGLIFE

C3 5w30

CODE: 7707

A fully synthetic high performance mid SAPS, low friction, fuel efficient engine oil. Particularly recommended by Mercedes Benz and BMW. Provides a reduction in friction of up to 27% and a reduction in wear of up to 14% compared to other 5w30 C3 grades.

**FULLY SYNTHETIC
ACEA C3
API SN, CF**



EE LONGLIFE ECO

5w30

CODE: 7706

Suitable for use in the very latest Ford petrol and diesel engines meeting the very latest European emission standards. A fully synthetic high performance, low friction, fuel efficient engine oil. Provides a reduction in friction of up to 53% and a reduction in wear of up to 50% compared to other 5w30 ECO grades.

**FULLY SYNTHETIC
ACEA A5/B5
API SL, CF**



EE SEMI SYNTHETIC

10w40

CODE: 7708

A semi synthetic high performance, low friction, fuel efficient engine oil. Recommended for use in modern petrol and diesel engines. Provides a reduction in friction of up to 60% and a reduction in wear of up to 42% compared to other standard semi synthetic 10w40 grades.

**SEMI SYNTHETIC
ACEA A3/B3, A3/B4
API SL, CF**

PREMIUM

Our premium range includes both fully and semi-synthetic oils, and focuses on maximising fuel economy whilst minimising engine wear.

Oil viscosity is maintained even under the most severe of operating conditions, ensuring maximum engine protection.

The range provides a wide variety of formulations, compatible with catalysts and diesel particulate filters, with a selection to suit the vast majority of engines.

For details of our full approvals and performance specifications, please refer to pages 14

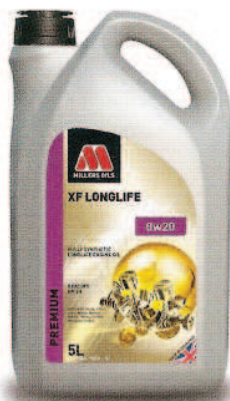

XF LONGLIFE

0w20

CODE: 7950

A high performance fully synthetic fuel efficient engine oil for makes such as Chrysler, Honda, Lexus, Mazda, Mitsubishi, Nissan, Proton, Subaru, Suzuki and Toyota.

**FULLY SYNTHETIC
API SN**



XF LONGLIFE

0w30

CODE: 7858

A high performance fully synthetic fuel efficient engine oil suitable for the latest Volvo petrol and diesel engine vehicles. Also, listed by certain Dacia, Honda, Mazda, Mitsubishi and Renault models.

**FULLY SYNTHETIC
ACEA A5/B5
API SL, CF**



XF LONGLIFE

0w40

CODE: 7725

A high performance fully synthetic petrol and diesel engine oil. Suitable for use in high performance vehicles such as BMW, Mercedes-Benz, Porsche, Nissan GT-R 35, Ford Focus RS 2.5.

**FULLY SYNTHETIC
ACEA A3/B4
API SN, CF**



XF LONGLIFE

5w30

CODE: 5862

A high performance fully synthetic mid SAPS engine oil suitable for the latest technology petrol and diesel engines. For use in most VAG petrol and diesel engines, and meeting the latest European emissions standards. For use in most VAG petrol and diesel engines.

**FULLY SYNTHETIC
ACEA C3**



XF LONGLIFE
5W40
CODE: 7640

A high performance fully synthetic petrol and diesel engine oil. Suitable for use in a range of applications including PD, VW 'Pumpe Düse' engines, VAG and some Ford vehicles.

FULLY SYNTHETIC
ACEA C3
API SN, CF



XF LONGLIFE
5W50
CODE: 7726

A high performance fully synthetic petrol and diesel engine oil formulated to meet the requirements of current and late model car engines operating under severe conditions.

FULLY SYNTHETIC
ACEA C3
API SN, CF



XF LONGLIFE
C1 5W30
CODE: 6228

A high performance fully synthetic low SAPS engine oil. Manufacturer requirement for latest Mazda and Mitsubishi diesel engines with DPF's, as well as the M2C934-B and Jaguar Land Rover STJLR, 03.5005 oil specifications.

FULLY SYNTHETIC
ACEA C1



XF LONGLIFE
C2 0W30
CODE: 7997

A high performance fully synthetic mid SAPS engine oil suitable for the latest petrol and diesel engine technology. Meets Euro IV/V/VI emission standard requiring ACEA C2 specification.

FULLY SYNTHETIC
ACEA C2
API SN, CF



XF LONGLIFE
C2 5W30
CODE: 6229

A high performance fully synthetic mid SAPS engine oil. Suitable for many Peugeot, Citroën and Renault vehicles, and preferred grade for Fiat, Alfa Romeo, Chevrolet, Lancia, Lexus and Toyota.

FULLY SYNTHETIC
ACEA C2,
API SN, CF



XF LONGLIFE
C3 0W30
CODE: 7998

A high performance fully synthetic mid SAPS engine oil suitable for the latest technology petrol and diesel engines. Meets Euro IV/V/VI emissions standards requiring ACEA C3 specification.

FULLY SYNTHETIC
ACEA C3
API SN, CF



XF LONGLIFE
C3 5W30
CODE: 6230

A high performance fully synthetic mid SAPS engine oil. Particularly recommended by Mercedes-Benz and BMW for use with variable service intervals and other vehicles that require a fuel-efficient lubricant.

FULLY SYNTHETIC
ACEA C3
API SN, CF



XF LONGLIFE
C4 5W30
CODE: 6231

A high performance fully synthetic low SAPS engine oil suitable for latest Renault diesel engines with diesel particulate filters.

FULLY SYNTHETIC
ACEA C4

PREMIUM ENGINE OILS



XF LONGLIFE
EB 5w30
CODE: 7779

A high performance fully synthetic fuel efficient engine oil to the Ford WSS-M2C948-B specification.

FULLY SYNTHETIC
ACEA C5
API SN, CF



XF LONGLIFE
Eco 5w30
CODE: 6221

A high performance fully synthetic engine oil. Suitable for use in Ford petrol and diesel engines where a 5w30 grade is specified.

FULLY SYNTHETIC
ACEA A5/B5
API SL, CF

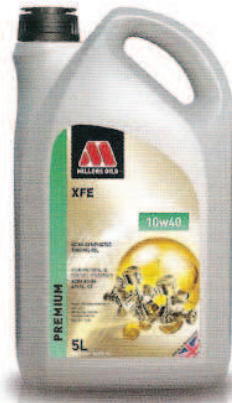

XFE
10w40
CODE: 5405

A high quality semi synthetic engine oil of SAE 10w40 viscosity. Recommended for use in diesel and petrol engines fitted to cars and light vans. Suitable for both turbo charged and non-turbo engines.

SEMI SYNTHETIC
ACEA A3/B4
API SL/CF

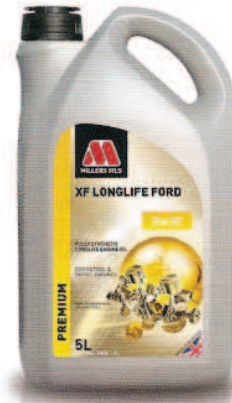

XF LONGLIFE
0w30 Ford
CODE: 8045

A lower viscosity fully synthetic oil for the modern engine that provides fuel efficiency. Particularly recommended and formulated for Ford engines.

FULLY SYNTHETIC
ACEA C2



XF LONGLIFE
0w20 14 F
CODE: 8046

A lower viscosity fully synthetic oil that provided fuel efficiency for the modern engine. Particularly recommended and formulated for BMW and Jaguar Land Rover engines.

FULLY SYNTHETIC
ACEA C5



XF LONGLIFE
0w20 Volvo
CODE: 8047

A lower viscosity fully synthetic oil for the modern engine that provides fuel efficiency. Particularly recommended and formulated for Volvo engines.

FULLY SYNTHETIC
ACEA C5



XF LONGLIFE
0w30 12 FE
CODE: 8048

A lower viscosity fully synthetic oil for the modern engine that provides fuel efficiency. Particularly recommended and formulated for BMW and Jaguar Land Rover engines.

FULLY SYNTHETIC
ACEA C2



XF LONGLIFE
0w20 VW
CODE: 8049

A lower viscosity fully synthetic oil for the modern engine that provides fuel efficiency. Particularly recommended and formulated for Volkswagen engines.

FULLY SYNTHETIC
ACEA C5

PROFESSIONAL

Our professional Trident engine oils stand for quality and value. Developed principally for professional and trade users, all oils in the range surpass manufacturers standards and are ideal for high volume use in the workshop.

Formulated to meet the demanding requirements of today's engines, our professional range of oils provides improved fuel economy, lower emissions and good wear protection to give longer engine life and covers over 94% of the passenger car vehicle parc.

For details of our full approvals and performance specifications, please refer to page 15



TRIDENT
5w30
CODE: 5995

A semi synthetic high performance engine oil formulated for engines requiring a 5w30 grade including Ford and many Japanese models.

SEMI SYNTHETIC
ACEA A3/B3, A3/B4
API SL, CF



TRIDENT
10w40
CODE: 5991

A high quality semi synthetic engine oil for cars and light vans. For use in more modern petrol and diesel vehicles where advantage can be taken of lighter lower viscosity oils. Suitable for turbo charged engines.

SEMI SYNTHETIC
ACEA A3/B3, A3/B4
API SL, CF



TRIDENT
5w40
CODE: 7625

A fully synthetic engine oil especially formulated for modern high performance vehicles. Also suitable for turbo charged engines.

FULLY SYNTHETIC
ACEA A3/B3, A3/B4
API SL, CF



TRIDENT
LONGLIFE
5w30
CODE: 5999

A high performance mid SAPS fully synthetic petrol and diesel engine oil, covering ACEA C2 + C3 specifications. Particularly recommended for use in vehicles using variable service intervals.

FULLY SYNTHETIC
ACEA C2, C3
API SN, CF



TRIDENT
LONGLIFE
5w40
CODE: 6124

A high performance fully synthetic petrol and diesel engine oil particularly recommended for use in vehicles using variable service intervals and those that need a fuel efficient oil.

FULLY SYNTHETIC
ACEA C3
API SN, CF



TRIDENT
LONGLIFE FUEL
ECONOMY
5w30
CODE: 8058

A high performance fully synthetic petrol and diesel engine oil suitable for use in Ford and Jaguar Land Rover engines where a 5w30 grade is specified.

FULLY SYNTHETIC
ACEA A5/B5
API SL, CF

TRANSMISSION OILS

Millers Oils has an extensive range of transmission oils for both manual gearboxes and automatic transmission systems. All of these are designed to meet the latest Original Equipment Manufacturer (OEM) specifications in cars and light vans.

Millers Oils transmission products are formulated with a special blend of additives as well as optimised viscosities to reduce the friction in a gearbox caused by high loads, where the oil alone cannot effectively form a protective layer between meshing parts.



EE TRANSMISSION 75w90 CODE: 7709

A fully synthetic high performance, low friction, fuel efficient transmission oil. Part of the Millers Oils NANODRIVE low friction technology range.

FULLY SYNTHETIC
API GL4, GL5



TRX 75w90 CODE: 5522

A semi synthetic transmission oil incorporating extreme pressure additives.

SEMI SYNTHETIC
API GL4, GL5



TRX SYNTH 75w80 GL5 CODE: 7765

A fully synthetic transmission oil to provide maximum protection and fuel economy.

FULLY SYNTHETIC
API GL4, GL5



TRX SYNTH 75w90 CODE: 5252

A fully synthetic transmission oil to provide maximum protection and fuel economy.

FULLY SYNTHETIC
API GL4, GL5



TRX SYNTH 75W CODE: 7999

A fully synthetic manual transmission oil to provide maximum protection and fuel economy.

FULLY SYNTHETIC
API GL4
BMW MTF LT-3
Ford WSS-M2C200-D2
VW G 052 171
VW G 052 178
VW G 052 512
VW G 060 726



EP 80w90 CODE: 5320

A high quality mineral oil formulation suitable for many synchromesh and constant mesh gearboxes, which require this type of specification.

MINERAL
API GL4



MILLERMATIC ATF 8 SPEED

CODE: 8035

Premium automatic transmission fluid technology blended into selected synthetic base fluids for use in automatic transmissions and other equipment.

**BMW 83 222 152 426
VW G 060162
ZF Lifeguard 8**



MILLERMATIC ATF CVT

CODE: 7767

Premium fully synthetic automatic transmission fluid for use in continuously variable transmissions (CVT).

**Audi/VW TL 52180, G 052 180
GM/Saturn DEX CVT
Hyundai CVTF
Mitsubishi CVT-J1/SP-III
Suzuki TC/NS-2/CVT**

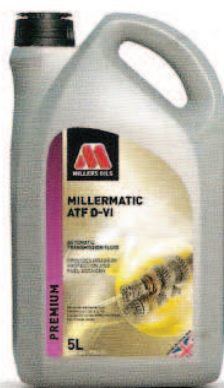

MILLERMATIC ATF D-VI

CODE: 7752

A premium fully synthetic automatic transmission fluid for GM automatic transmissions from 2006 onwards.

**GM Dexron VI, IiIG & H, IID
Also suitable for certain models of:
BMW, Alfa Romeo, Fiat,
Nissan, Honda**



MILLERMATIC ATF DCT-DSG

CODE: 7742

A premium fully synthetic automatic transmission fluid for use in Dual Clutch Transmission gearboxes, DSG or DCT wet clutch applications.

**VAG
Porsche PDK
BMW Getrag DCT
MB 7 speed A & B class
PSA DCT
Fiat
Volvo
FFL2, FFL3, FFL4**



MILLERMATIC ATF MB

CODE: 7740

A premium fully synthetic automatic transmission fluid for certain models of Mercedes Benz.

**Mercedes-Benz 236.14,
236.12**



MILLERMATIC ATF SP III-WS

CODE: 6213

A premium fully synthetic automatic transmission fluid formulated to meet the high performance levels required by Japanese and Korean manufacturers.

**Mitsubishi SP II, SP III
Hyundai and Kia
Rebrands of Mitsubishi Fluids
Toyota T-III, T-IV, WS
Honda ATF Z1
Nissan MATIC-D, MATIC-J
JASO M315 1A
Subaru Special ATF
GM Dexron III
Ford Mercon
Mopar +3, Mopar +4**



MILLERMATIC ATF UN

CODE: 5386

An automatic transmission and power steering fluid for use in automatic transmission and power steering systems.

**GM Dexron IID
Ford M2C 138CJ, M2C 166H
Mercedes-Benz 236.1 236.5,
236.6, 236.7**



MILLERMATIC ATF DM

CODE: 5548

Premium automatic transmission fluid technology blended into selected synthetic base fluids

**GM Dexron IIIH
Ford Mercon
Mercedes-Benz 236.9,
236.10
ZF TE ML 02F, 04D, 03D
09, 11B, 14B
Allison C4 TES 389**

FUEL TREATMENTS

ECOMAX

Available for both petrol and diesel engines these Ecomax treatments are beneficial to all road cars.

BENEFITS INCLUDE:

- Improves fuel economy and efficiency
- Cleans injectors
- Reduces emissions
- Maintains clean conditions within the engine and fuel system
- Cost effective
- Convenient to use



DIESEL

Our Diesel Power Ecomax is a cetane booster and detergent package adding up to 5 cetane numbers* to fuel. Reduces combustion chamber deposits, reduces the possibility of DPF blockage and also enhances lubricity.

Treatment rate is 1 part Ecomax to 1000 parts fuel (1ml/l).

Available in 500ml (6204) multishot bottle which treats 10 x 50L tanks and 250ml (6206) one shot bottle

*The 500ml adds up to 4 cetane numbers



PETROL

Our Petrol Power Ecomax is an octane booster and detergent package adding 3 octane numbers* to unleaded fuel. Reduces combustion chamber deposits and improves inlet manifold and valve cleanliness. Reduces emissions, maintains catalyst efficiency and may invigorate catalytic converters.

Treatment rate is 1 part Ecomax to 1000 parts fuel (1ml/l).

Available in 500ml (6205) multishot bottle which treats 10 x 50L tanks and a 250ml (6207) one shot bottle

*The 500ml adds up to 2 octane numbers

TREATMENTS

For a 'good as new engine', try Millers Oils' premium treatments.

Millers Oils is one of the very few lubricant companies that also specialises in treatments. Our range is extensive, with products available for each sector of motoring to support a whole range of vehicles. Treatments are packed with enhancing and boosting qualities to bring your engine back to life. Long term benefits include improved response times and better fuel economy.

OTHER

LHM PLUS CODE: 5488

A green mineral based hydraulic fluid specially developed for Citroën cars. Miscible in all proportions with LHM (Liquide Hydraulique Mineral) and the mineral hydraulic fluids which match the old Citroën specifications.

PSA B71 2710
FORD ESN M6C 59A
ISO 7308

UNIVERSAL BRAKE FLUID DOT 4

CODE: 5391

A high boiling point brake fluid for all braking systems where a non-mineral fluids is required. Suitable for use in anti-lock brake (ABS) systems.

SAE J 1703, FMVSS 116
DOT 4

PERFORMANCE DOT 5.1 BRAKE FLUID

CODE: 7977

A long life fluid for all types of hydraulic actuated brake and clutch systems requiring this specification. Highly suited for ABS systems.

US FMVSS 116 DOT 5.1,
DOT 4, DOT 3
SAE J 1703, J 1704



DIESEL INJECTOR CLEANER AND PETROL INJECTOR CLEANER

DIESEL CODE: 7627
PETROL CODE: 7628

Maximum strength, highly concentrated cleaning agent developed to remove deposits from diesel/petrol fuel injection systems. Benefits include reducing engine emissions, improving torque, power, poor throttle response and rough idling as well as improving fuel economy.

Treats 60 litres. Available in 250ml.



DIESEL PARTICULATE CLEANER AND REGENERATOR

CODE: 7795

A one shot diesel additive designed to clean diesel particulate filters (DPFs) by reducing the regeneration temperature required to allow the trapped soot particles to be burnt off. Ensures a cleaner more efficient DPF restoring engine power and fuel economy. One 250ml bottle treats 60 litres of fuel. Can be used more frequently if DPF blocking is a problem.

Available in 250ml.



STOP LEAK CODE: 5619

A high quality product which can be added to engine or gear oil to help minimise leaks in all cars and light vans with petrol or diesel engines, gearboxes and axles. Helps maintain oil tightness in old or leaky seals.

Available in 250ml.



ENGINE FLUSH CODE: 5777

A non-solvent based high detergent engine flush which should be added to the engine oil before a drain and refill is due to take place. Suitable for use in all cars and light vans with petrol or diesel engines. Removes sludge and deposits from inside the engine. Maintains the internal cleanliness of your engine, reduces wear and increases engine life.

Available in 250ml.

WHICH OIL?

PREMIUM SPECIFICATION CHART

PRODUCT CODE	PRODUCT	PACK SIZES AVAILABLE	BASE OIL TYPE			
				API	ACEA	VW/AUDI
7877	EE Longlife 5w30	1L, 5L, 25L, 199L	Fully Synthetic, Mid SAPS	SN, CF	C3	VW 504 00, 507 00
7806	EE Longlife 5w40	1L, 5L, 25L, 199L	Fully Synthetic, Mid SAPS	SN, CF	C3	VW 502 00, 505 01
7707	EE Longlife C3 5w30	1L, 5L, 25L, 199L	Fully Synthetic, Mid SAPS	SN, CF	C3	VW 502.00, 505.01
7706	EE Longlife ECO 5w30	1L, 5L, 25L, 199L	Fully Synthetic	SL, CF	A5, B5	-
7708	EE Semi Synthetic 10w40	1L, 5L, 25L, 199L	Semi Synthetic	SL, CF	A3, B3 / A3, B4	VW 502 00, 505 00
5405	XFE 10w40	1L, 5L, 25L, 199L	Semi Synthetic	SL, CF	A3, B4	VW 502 00, 505 00
7950	XF Longlife 0w20	1L, 5L, 25L, 199L	Fully Synthetic	SN		-
7858	XF Longlife 0w30	1L, 5L, 25L, 199L	Fully Synthetic	SL, CF	A5, B5	-
7725	XF Longlife 0w40	1L, 5L, 25L, 199L	Fully Synthetic	SN, CF	A3, B4	VW 502 00, 505 00
7640	XF Longlife 5w40	1L, 5L, 25L, 199L	Fully Synthetic, Mid SAPS	SN, CF	C3	VW 502.00, 505.01
7726	XF Longlife 5w50	1L, 5L, 25L, 199L	Fully Synthetic, Mid SAPS	SN, CF	C3	-
6228	XF Longlife C1 5w30	1L, 5L, 25L, 199L	Fully Synthetic, Low SAPS	-	C1	-
7997	XF Longlife C2 0w30	1L, 5L, 25L, 199L	Fully Synthetic, Mid SAPS	SN, CF	C2	-
6229	XF Longlife C2 5w30	1L, 5L, 25L, 199L	Fully Synthetic, Mid SAPS	SN, CF	C2	-
7998	XF Longlife C3 0w30	1L, 5L, 25L, 199L	Fully Synthetic, Mid SAPS	SN, CF	C3	-
6230	XF Longlife C3 5w30	1L, 5L, 25L, 199L	Fully Synthetic, Mid SAPS	SN, CF	C3	VW 502.00, 505.01
6231	XF Longlife C4 5w30	1L, 5L, 25L, 199L	Fully Synthetic, Low SAPS	-	C4	-
7779	XF Longlife EB 5w20	1L, 5L, 25L, 199L	Fully Synthetic	SN, CF	A1, B1	-
6221	XF Longlife ECO 5w30	1L, 5L, 25L, 199L	Fully Synthetic	SL, CF	A5, B5	-
8045	XF Longlife 0w30 Ford	1L, 5L, 25L, 199L	Fully Synthetic	-		-
8046	XF Longlife 0w20 14 FE	1L, 5L, 25L, 199L	Fully Synthetic	-	C5	-
8047	XF Longlife 0w20 Volvo	1L, 5L, 25L, 199L	Fully Synthetic	-	C5	-
8048	XF Longlife 0w30 12 FE	1L, 5L, 25L, 199L	Fully Synthetic	-	C2	-
8049	XF Longlife 0w20 VW	1L, 5L, 25L, 199L	Fully Synthetic	-	C5	VW 508.00/509.00, VW TL 52577
5862	XF Longlife 5w30	1L, 5L, 25L, 199L	Fully Synthetic, Mid SAPS	-	C3	VW 504.00, 507.00

SPECIFICATIONS

MB	BMW	RN	FIAT	FORD	GM
MB 229.51	BMW Longlife-04	-	-	-	-
MB 229.31, MB 229.51	BMW Longlife-04	-	Fiat 9.55535-5S	Ford M2C917-A	GM dexos 2
-	BMW Longlife-04	-	Fiat 9.55535-5S	-	GM dexos 2
-	-	RN0700	-	Ford M2C913-D, M2C913-C, M2C913-B	-
MB 229.1	-	RN0700	-	-	-
MB 229.1	-	RN0700	-	-	-
-	-	-	-	-	-
-	-	-	-	-	-
MB 229.3, MB 229.5	BMW Longlife-01	RN0700, 0710,	-	Ford WSS-M2C937-A	-
MB 229.31, MB 229.51	BMW Longlife-04	-	Fiat 9.55535-S2	M2C917-A	GM dexos 2
MB 229.51	-	-	-	-	-
-	-	-	-	Ford M2C934-B	-
-	BMW Longlife 12FE	-	Fiat 9.55535-GS1, 9.55535-DS1	-	-
-	-	-	Fiat 9.55535-S1	-	-
MB 229.51	BMW Longlife-04	-	-	-	GM dexos 2
MB-Approval 229.51	BMW Longlife-04	-	Fiat 9.55535-S3	-	GM dexos 2
-	-	Renault RN0720 [diesel and DPF]	-	-	-
-	-	-	-	Ford WSS-M2C948-B	-
-	-	RN0700	-	Ford M2C913-D, M2C913-C, M2C913-B	-
-	-	-	-	Ford M2C950-A	-
-	BMW Longlife-14 FE+	-	-	-	-
-	-	-	-	-	-
-	BMW Longlife-12 FE	-	-	-	-
-	-	-	-	-	-
MB 229.51	-	-	-	-	-

WHICH OIL?

TRIDENT SPECIFICATION CHART

PRODUCT CODE	PRODUCT	PACK SIZES AVAILABLE	BASE OIL TYPE	SPECIFICATIONS										EXAMPLES OF VEHICLES	
				API	ACEA	VW/AUDI	MB	BMW	RN	FIAT	FORD	GM	OTHER		
5995	Trident 5w30	1L, 5L, 25L, 199L	SEMI SYNTHETIC	SL, CF	A3/B3, A3/B4	VW 500.00/VW 501.01 VW 502.00/ VW505.00	MB 229.1 MB 229.3 MB 229.5			RN0700		Ford M2C913-A M2C913-B	GM-LL-A-025 GM-LL-B-025		Suitable for engines requiring 5w30 including Ford and many Japanese models
7625	Trident 5w40	1L, 5L, 25L, 199L	FULLY SYNTHETIC	SL, CF	A3/B3, A3/B4	VW 502.00/505.00	MB 229.1 MB 229.3 MB 229.5	BMW Longlife-01	RN0700 RN0710		Fiat 9.55535-M2 Fiat 9.55535-N2 Fiat 9.55535-Z2		GM-LL-A-025 GM-LL-B-025		
5991	Trident 10w40	1L, 5L, 25L, 199L	SEMI SYNTHETIC	SL, CF	A3/B3, A3/B4	VW 500.00/501.01 VW 502.00/505.00	MB 229.1 MB 229.3		RN0700		Fiat 9.55535-G2			MTF-94 PSA B71 2291 PSA B71 2295 PSA B71 2300	
5999	Trident Longlife 5w30	1L, 5L, 25L, 199L	FULLY SYNTHETIC	SN, CF	C2, C3	VW 502.00/505.00 VW 502.00/505.01 VW 504.00/507.00	MB 229.31	BMW Longlife-04			Fiat 9.55535-S3		GM Dexos 2	Audi, VW, Seat, Skoda, Porsche C30 PSA B71 2290	Fiat, Alfa Romeo, Chevrolet, Honda, Hyundai, Kia, Lexus, Toyota, Nissan, Peugeot, Citroen
6124	Trident Longlife 5w40	1L, 5L, 25L, 199L	FULLY SYNTHETIC	SN, CF	C3	VW 502.00/505.00 VW 502.00/505.01	MB 226.5 MB 229.31 MB 229.51	BMW Longlife-04	RN0700 RN0710		Fiat 9.55535-S2	Ford M2C917-A	GM Dexos 2	Porsche A40	
8058	Trident Longlife Fuel Economy 5w30	1L, 5L, 25L, 199L	FULLY SYNTHETIC	SL, CF	A5/B5				RN0700		Ford M2C912-A1 M2C913-A M2C913-B M2C913-C M2C913-D M2C929-A M2C930-A	Chrysler MS 6395	Jaguar Land Rover STJLR.03.5003 ILSAC GF-4		

FOR PRODUCT SPECIFICATION INFO & TECHNICAL HELP PLEASE CALL US ON +44 (0) 1484 475060



WHICH OIL?

Not sure which oil to use? The Millers Oils 'Which Oil?' guide is frequently used and can be found on our website. Users can find out which oil they need by either entering their registration plate or typing in the make and model. The latest version of 'Which Oil?' is the most comprehensive version that we have ever published; it lists more options for better flexibility which means Millers Oils is able to fulfill customers' requirements.

To use our Which Oil guide visit: www.millersoils.co.uk

Millers Oils Premium Automotive

Millers Oils Ltd
Brighouse, West Yorkshire,
HD6 3DP, UK
T: +44 (0) 1484 713201
F: +44 (0) 1484 721263
E: sales@millersoils.co.uk

www.millersoils.co.uk



MillersOilsLtd

All products and information are reflective of the latest specifications at the time of going to print. The company reserves the right to change formulations and specifications without prior notice.

REF / AUTO / 2018 / V2

